

Location:



## T1800-PB-4 with Ductile Iron Integral Rail



### Specification:

MIFAB®'s T1800-PB-4 series channels shall be 39.4" (1000 mm) long with a 12" (300 mm) internal width. Interconnecting channels sections are made from high strength Polymer Concrete and are only available in non-sloping (neutral) channels. Each channel comes with a standard ductile iron edge rail which is mechanically embedded in the channel. Only available in Load Class F.

Installation devices, plastic end cap/outlet cap, and catch basins are available accessories. Grates (separate Specification Sheets) are available only in Load Class F. Grates utilize the patented "Profix" locking mechanism.

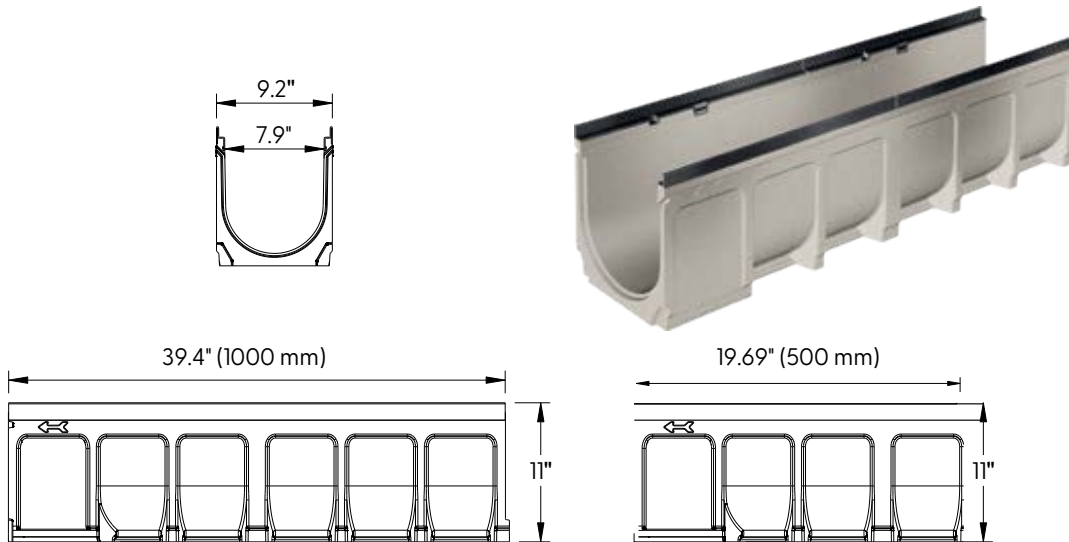

CHANNEL MODEL NUMBER	BODY TYPE Sloped - .5% Neutral - 0%	INVERT BODY DEPTH		BODY DEPTH OVERALL		MAXIMUM FLOW RATE GPM	WEIGHT (LESS GRATE) LBS.
		E1 (Min.)	E2 (Max.)	E1 (Min.)	E2 (Max.)		
T1800N-PB-4	Neutral	10.04"	10.04"	11.82"	11.82"	837.39	76.28

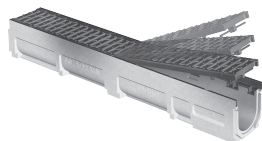

### PROFIX ADVANTAGE

The MEA polymer concrete channels with ductile iron grates have been designed for our universal PROFIX grate locking mechanism. The system (channel and grate) provides longitudinal shift protection.

Job Name: _____	Page No: _____
Section No: _____	Contractor: _____
Schedule No: _____	Purchase Order No: _____

Revision Date: 2022/02/22

CALIFORNIA PROPOSITION 65 WARNING. This product contains chemicals known to the State of California to cause cancer and birth defects or other reproductive harm.

MIFAB reserves the right to make changes in material and design without formal notice and obligation. USA: 1-800-465-2736 www.mifab.com CAN: 1-800-387-3880